

Compact and Affordable Network Solution



VGA Network Fixed Dome Camera

SND-1011

The SND-1011 is a discreet general purpose VGA network dome camera suitable for a wide range of internal applications. With the Samsung Techwin WiseNetS DSP chipset at its core, which delivers a host of advanced features including face detection analytics, third generation Samsung Super Noise Reduction (SSNR^{III}) to eliminate image noise in low light conditions, and Samsung Super Dynamic Range (SSDR); it has an analogue video output port enabling conventional analogue control device to make set-up on site easy. Its compact design makes the SND-1011 especially suitable for small applications such as convenience stores and retail shops.

- 30fps at VGA(640x480) resolution
- Built-in 3mm fixed lens
- H.264, MJPEG Dual Encoding
- Multiple Streaming
- Day and Night Function (Software)
- SSDR, SSNR^{III}
- Motion Detection, Face Detection

VGA Network Fixed Dome Camera

SND-1011



Specifications



	SND-1011N	SND-1011P
VIDEO		
Imaging Device	1/4" PS CMOS	
Total Pixels	680(H) x 512(V)	
Effective Pixels	640(H) x 480(V)	
Scanning System	Progressive	
Min. Illumination	0.7Lux (F1.2)	
S / N Ratio	50dB	
Video Out	DIP connector type, for installation	
LENS		
Focal Length (Zoom Ratio)	3mm fixed	
Max. Aperture Ratio	F2.0	
Angular Field of View	H : 70°, V : 50°	
Min. Object Distance	40mm (0.13ft)	
Mount Type	Board type	
PAN / TILT / ROTATE		
Pan Range	0° ~ 355°	
Tilt Range	17° ~ 90°	
Rotate Range	0° ~ 355°	
OPERATIONAL		
Camera Title	Off / On (Displayed up to 15 characters)	
Day & Night	Auto (S/W) / Color / B/W / External B/W	
Backlight Compensation	Off / BLC	
Contrast Enhancement	SSDR (Samsung Super Dynamic Range) (Off / On)	
Digital Noise Reduction	SSNRll (2D+3D noise filter) (Off / On)	
Motion Detection	Off / On (4 programmable zones)	
Privacy Masking	Off / On (32ea 4 points polygonal)	
Sens-up (Frame Integration)	Off / Auto (2x ~ 60x)	
Gain Control	Off / Low / Medium / High	
White Balance	ATW / AWC / Manual / Indoor / Outdoor	
Electronic Shutter Speed	Auto / A.FLK / Manual (60x ~ 1/12000sec)	
Flip / Mirror	Off / On	
Intelligent Video Analytics	Face detection	
Alarm I/O	Input 1ea	
NETWORK		
Ethernet	RJ-45 (10/100BASE-T)	
Video Compression Format	H.264, MJPEG	
Resolution	4 : 3 Mode - 640 x 480 / 320 x 240 / 160 x 120	
Max. Framerate	Max. 30fps at all resolutions	
Video Quality Adjustment	H.264 : Compression level, Target bitrate level control MJPEG : Quality level control	
Bitrate Control Method	H.264 : CBR or VBR, MJPEG : VBR	
Streaming Capability	Multiple streaming (Up to 10 profiles)	
IP	IPv4, IPv6	
Protocol	TCP/IP, UDP/IP, RTP(UDP), RTP(TCP), RTSP, NTP, HTTP, HTTPS, SSL, DHCP, PPPoE FTP, SMTP, ICMP, IGMP, SNMPv1/v2c/v3(MIB-2), ARP, DNS, DDNS, QoS, ONVIF	
Security	HTTPS(SSL) login authentication, Digest login authentication, IP address filtering, User access log, 802.1x Authentication	
Streaming Method	Unicast / Multicast	
Max. User Access	5 users at unicast mode	
Memory Slot	Micro, SD/SDHC memory slot	
ONVIF Conformance	Yes	
Webpage Language	English, French, German, Spanish, Italian, Chinese, Korean, Russian, Japanese, Swedish, Danish, Portuguese, Turkish, Polish, Czech, Rumanian, Serbian, Dutch, Croatian, Hungarian, Greek	
Web Viewer	Supported OS : Windows XP / VISTA / 7, MAC OS Supported Browser : Internet Explorer 7.0 or Higher, Firefox, Google Chrome, Apple Safari	
Central Management Software	NET-i viewer	
ENVIRONMENTAL		
Operating Temperature / Humidity	-10°C ~ +50°C (+14°F ~ +122°F) / 20% ~ 80% RH	
ELECTRICAL		
Input Voltage / Current	12V DC / PoE (IEEE802.3af)	
Power Consumption	Max. 5W	
MECHANICAL		
Color / Material	Ivory / Plastic	
Dimensions (WxH)	Ø107.6 x 83.7mm (Ø4.24" x 3.3")	
Weight	285g (0.63 lb)	

Dimensions

Unit : mm (inch)

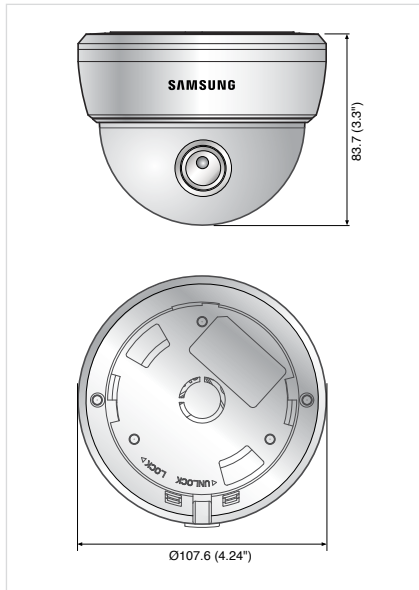

The Eco mark represents Samsung Techwin's will to create environment-friendly products, and indicates that the product satisfies the EU RoHS Directive.

Design and specifications are subject to change without notice.



SAMSUNG TECHWIN CO., LTD.

701, Sampyeong-dong, Bundang-gu, Seongnam-si, Gyeonggi-do Korea 463-400
Tel : +82-70-7147-8741~8749, 8752~8760 Fax : +82-31-8018-3745
www.samsungsecurity.com www.samsungcctv.com

SAMSUNG TECHWIN AMERICA INC.

100 Challenger Rd. Suite 700 Ridgefield Park, NJ 07660
Toll Free : +1-877-213-1222 Direct : +1-201-325-6920
Fax : +1-201-373-0124
www.samsungcctvusa.com

SAMSUNG TECHWIN EUROPE LTD.

Samsung House, 1000 Hillwood Drive, Hillwood Business Park
Chertsey, Surrey, UNITED KINGDOM KT16 0PS
Tel : +44-1932-45-5300 Fax : +44-1932-45-5325

TIANJIN SAMSUNG TECHWIN OPTO-ELECTRONICS CO., LTD.

No.11 Wei 6 Street, Micro-Electronic Industrial Park
Jingang Road, Tianjin, P.R. CHINA 300385
Tel : +86-22-23887788 Fax : +86-22-23887788

■ DISTRIBUTED BY

